

**IMPORTANT!
DO NOT DESTROY**



Installation and Maintenance Manual

with **Safety Information**
and **Parts List**

RECOMMENDED SPARE PARTS HIGHLIGHTED IN GRAY

Model C

Effective November, 1998
(Supersedes January, 1995)

Bulletin # 434



HYTROL CONVEYOR CO., INC.

Jonesboro, Arkansas
St. Louis, Missouri
Manteca, California

● Table of Contents

Warning Signs2

INTRODUCTION

Receiving and Uncrating3

INSTALLATION

Installation Safety Precautions3

Support Installation4-5

Ceiling Hanger Installation6

Belt Installation7

Electrical Equipment8

OPERATION

Operation Safety Precautions9

Conveyor Start-Up9

Sequence of Operation9

Belt Tracking10-11

MAINTENANCE

Maintenance Safety Precautions12

Reducer Maintenance/Lubrication12

Bearing Lubrication12

Chain Lubrication12

Drive Chain Alignment and Tension13

Trouble Shooting14

Preventive Maintenance Checklist15

REPLACEMENT PARTS

How to Order Replacement Parts15

Model C Parts Drawing & List16-17

Undertrussing-Model C18-19

Powered Feeders20-21

● Warning Signs

In an effort to reduce the possibility of injury to personnel working around HYTROL conveying equipment, warning signs are placed at various points on the equipment to alert them of potential dangers. Please check equipment and note

all warning signs. Make certain your personnel are alerted to and obey these warnings. Shown below are typical signs that are attached to this equipment.



PLACED NEXT TO DRIVE, BOTH SIDES.



PLACED ON TERMINATING ENDS



PLACED ON ALL POWERED CONVEYORS NEAR DRIVE AND/OR CONTROLS.



PLACED WHERE POP-OUT ROLLERS ARE USED



PLACED ON ALL CHAIN GUARDS.



PLACED ON 20 FT. INTERVALS, BOTH SIDES.



PLACED AT DRIVE OF ALL POWERED CONVEYORS.

INTRODUCTION



This manual provides guidelines and procedures for installing, operating, and maintaining your conveyor. A complete parts list is provided with recommended spare parts highlighted in gray. Important safety information is also provided throughout

the manual. For safety to personnel and for proper operation of your conveyor, it is recommended that you read and follow the instructions provided in this manual.

● Receiving and Uncrating

1. . . Check the number of items received against the bill of lading.
2. . . Examine condition of equipment to determine if any damage occurred during shipment.
3. . . Move all crates to area of installation.
4. . . Remove crating and check for optional equipment that may be fastened to the conveyor. Make sure these parts (or any foreign pieces) are removed.

NOTE: If damage has occurred or freight is missing, see the “Important Notice” attached to the crate.

INSTALLATION

● Installation Safety Precautions *for Conveyors and Related Equipment*

GUARDS AND GUARDING

Interfacing of Equipment. When two or more pieces of equipment are interfaced, special attention shall be given to the interfaced area to insure the presence of adequate guarding and safety devices.

Guarding Exceptions. Wherever conditions prevail that would require guarding under these standards, but such guarding would render the conveyor unusable, prominent warning means shall be provided in the area or on the equipment in lieu of guarding.

Guarded by Location or Position. Where necessary for the protection of employees from hazards, all exposed moving machinery parts that present a hazard to employees at their work station shall be mechanically or electrically guarded, or guarded by location or position.

When a conveyor passes over a walkway, roadway, or work station, it is considered guarded solely by location or position if all moving parts are at least 8 ft. (2.44 m) above the floor or walking surface or are otherwise located so that the employee cannot inadvertently come in contact with hazardous moving parts.

Although overhead conveyors may be guarded by location, spill guard, pan guards, or equivalent shall be provided if the product may fall off the conveyor for any reason and if personnel would be endangered.

HEADROOM

When conveyors are installed above exit passageways, aisles, or corridors, there shall be provided a minimum clearance of 6 ft. 8 in. (2.032 m) measured vertically from the floor or walking surface to the lowest part of the conveyor or guards. Where system function will be impaired by providing the minimum clearance of 6 ft. 8 in. (2.032 m) through an emergency exit, alternate passageways shall be provided.

It is permissible to allow passage under conveyors with less than 6 ft. 8 in. (2.032 m) clearance from the floor for other than emergency exits if a suitable warning indicates low headroom.

● Support Installation

Align conveyor section in proper sequence per match-marked stickers at each end (Figure 4A).

When using stationary support attach supports at points shown in drawings below. The conveyor's angle of incline will determine where the knee brace mounting brackets are to be placed.

NOTE: When attaching supports, hand tighten bolts only, as minor adjustments may be necessary in final installation.

FIGURE 4A

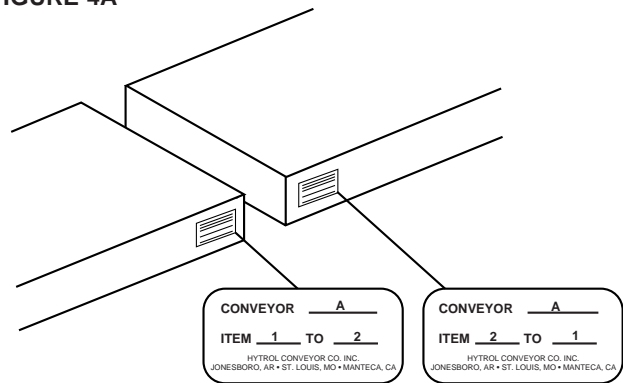

FIGURE 4B

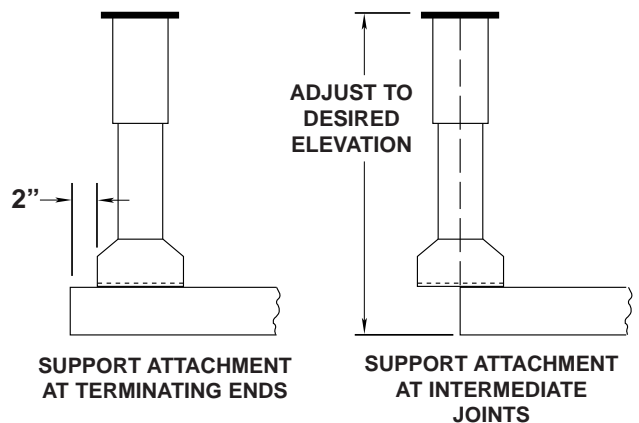
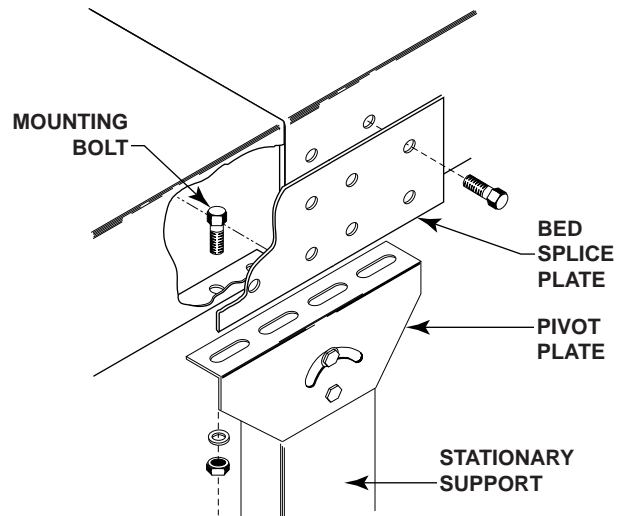

FIGURE 4C



● Model C Powered Feeder Parts List



See Page 15 For Information On
How To Order Replacement Parts

Recommended Spare Parts List Highlighted in Gray

Ref. No.	Part No.	Description
1	—	Bed Assembly
—	B-20077	33 in. Long, 20 in. OAW
—	B-20078	33 in. Long, 24 in. & 30 in. OAW (Specify)
—	B-04351	48 in. Long, 20 in. OAW
—	B-05592	48 in. Long, 24 in. & 30 in. OAW (Specify)
2	B-01884	Bed Spacer (Use on 48 in. Bed Only) (Specify OAW)
3	—	Conveyor Tail Pulley
—	B-22222	4 in. Dia. (Specify OAW)
—	B-22101	6 in. Dia. (Specify OAW)
4	—	Feeder Drive Pulley
—	B-22222	4 in. Dia. (Specify OAW)
—	B-22101	6 in. Dia. (Specify OAW)
5	—	Feeder Tail Pulley
—	B-22221	4 in. Dia. (Specify OAW)
—	B-21752	6 in. Dia. (Specify OAW)
6	—	3-Bolt Flange Bearing
—	010.102	1 in. Bore (4 in. Pulley)
—	010.103	1-3/16 in. Bore (6 in. Pulley)
7	—	Sprocket
—	028.119	50B 13 x 1 in. Bore (4 in. Pulley)
—	028.123	50B 15 x 1-3/16 in. Bore (6 in. Pulley)
8	090.203	Shaft Key—1/4 in. Sq. x 1 in. Long
9	029.101	#50 Riveted Roller Chain
10	029.201	#50 Connector Link
11	029.206	#50 Offset Connector Link
12	—	Pivot Plate
—	B-06170	4 in. Pulley
—	B-06173	6 in. Pulley
13	—	Chain Guard
—	B-06174-002	4 in. Pulley
—	B-06179-002	6 in. Pulley
14	040.312	Hex Head Bolt—3/8-16 x 4 in. Long
15	041.200	Hex Jam Nut—3/8-16
16	049.552	Wing Nut—3/8-16
17	—	Feeder Drive Plate—RH
—	B-09759-R	4 in. Pulley
—	B-09758-R	6 in. Pulley
18	—	Feeder Drive Plate—LH
—	B-09759-L	4 in. Pulley
—	B-09758-L	6 in. Pulley
19	—	Conveyor Take-Up Plate—RH
—	B-21349-R	4 in. Pulley.
—	B-21351-R	6 in. Pulley
20	—	Conveyor Take-Up Plate—LH
—	B-21349-L	4 in. Dia.
—	B-21351-L	6 in. Dia.
21	B-21347-R	Adjustment Plate Assembly—RH
22	B-21347-L	Adjustment Plate Assembly—LH
23	041.919	Acorn Bolt—3/8-16
24	042.919	Shoulder Bolt—1/2 in. Dia. x .312 in. Long
25	—	Nip Point Guard
—	B-09859	4 in. Dia. Pulley 20 in. & 24 in. OAW (Specify)
—	B-09860-030	6 in. Dia Pulley
26	—	Feeder Take-Up Plate—RH

Ref. No.	Part No.	Description
—	B-19616-R	4 in. Pulley
—	B-21351-R	6 in. Pulley
27	—	Feeder Take-Up Plate—LH
—	B-19616-L	4 in. Pulley
—	B-21351-L	6 in. Pulley
28	—	Adjustment Plate—RH
—	B-19619	4 in. Pulley
—	B-21347-R	6 in. Pulley
29	—	Adjustment Plate—LH
—	B-19619	4 in. Pulley
—	B-21347-L	6 in. Pulley
30	040.4065	Take-Up Bolt, 1/2-13 x 4 in. Long
31	041.201	Hex Jam Nut—1/2-13
32	—	Gravity Bracket
—	B-02623	4 in. Pulley
—	B-06210	6 in. Pulley
33	B-02624	Gravity Bar (Specify OAW)
34	B-02912	1 in. Dia. Pop-Out Roller (Specify OAW)
35	091.110	Cable Assembly
36	B-06742	2-1/8 in. Dia. Snub Roller (Specify OAW)
37	093.215	Return Roller Bracket
38	—	Snub Roller Guard (Specify OAW)
—	B-14443	33 in. Long Bed
—	B-13708	48 in. Long Bed
39	—	Snub Roller Guard Mounting Bracket
—	B-14445	33 in. Long Bed
—	B-13707	48 in. Long Bed
40	049.310	U-Type Speed Nut—1/4-20
41	—	Belt—Black Trackmate #529 FBS (Specify Width)
42	—	U1 Clipper Unibar Lacing (Specify Length)
43	—	#13 Lacing Pin (Specify Length)
44	—	MS Type Pivot Plate
—	B-00913	3-11/16 in. High
—	B-02112	1-9/16 in. High
45	—	Floor Support Frame
—	B-00914	6 In. High (Specify OAW)
—	B-12777	7 In. High (Specify OAW)
—	B-12778	8 In. High (Specify OAW)
—	B-00915	9 In. High (Specify OAW)
—	B-00916	11-1/2 In. High (Specify OAW)
—	B-00917	14-1/2 In. High (Specify OAW)
—	B-02098	18-1/2 In. High (Specify OAW)
—	B-00919	22-1/2 In. High (Specify OAW)
—	B-00921	32-1/2 In. High (Specify OAW)
—	B-00923	44-1/2 In. High (Specify OAW)
—	B-00925	56-1/2 In. High (Specify OAW)
—	B-02107	68-1/2 In. High (Specify OAW)
—	B-02109	78-1/2 In. High (Specify OAW)
—	B-02111	90-1/2 In. High (Specify OAW)
46	B-00911	Adjustable Foot Assembly (Specify Length)

● Model C Powered Feeder Parts Drawing

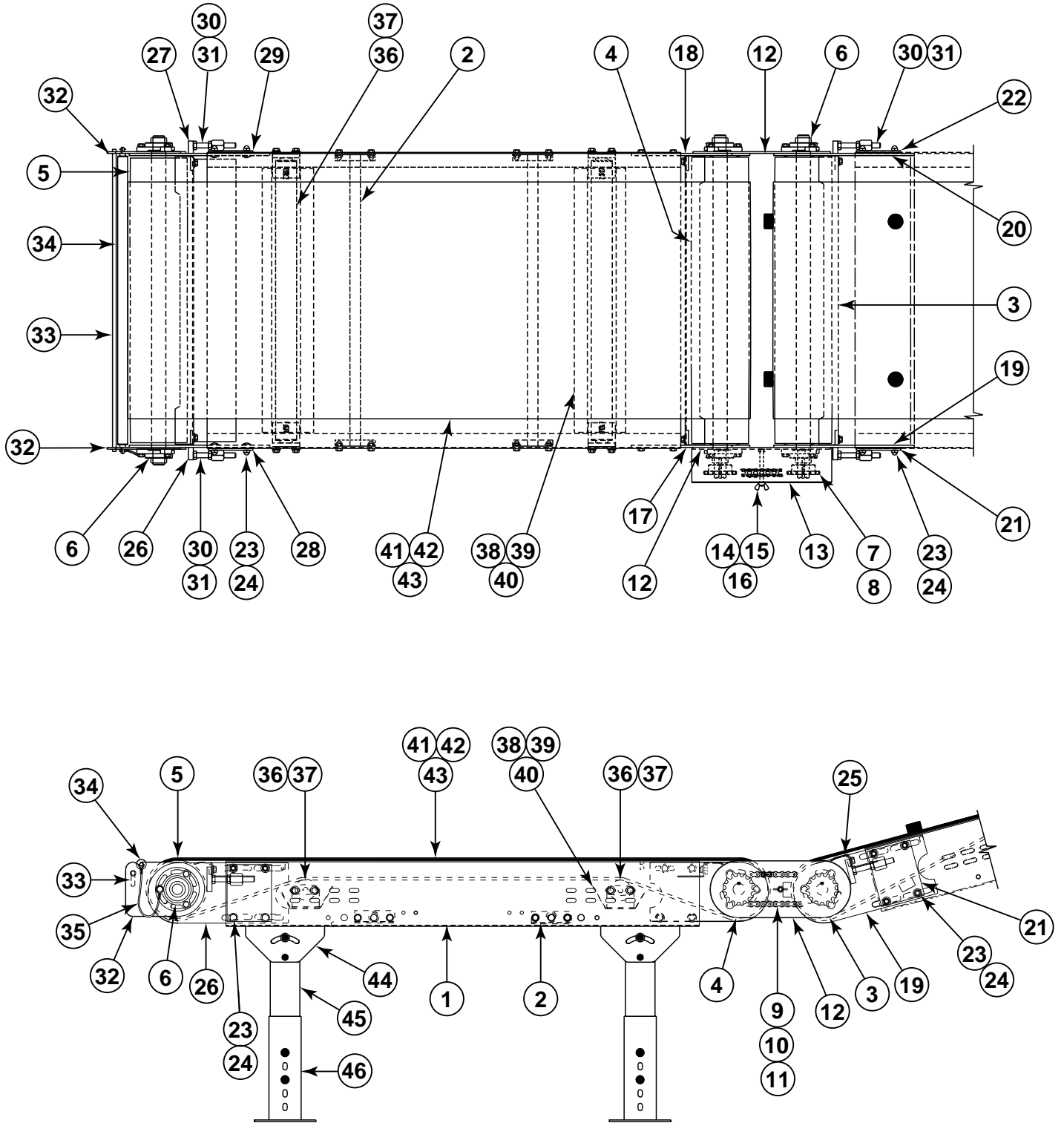
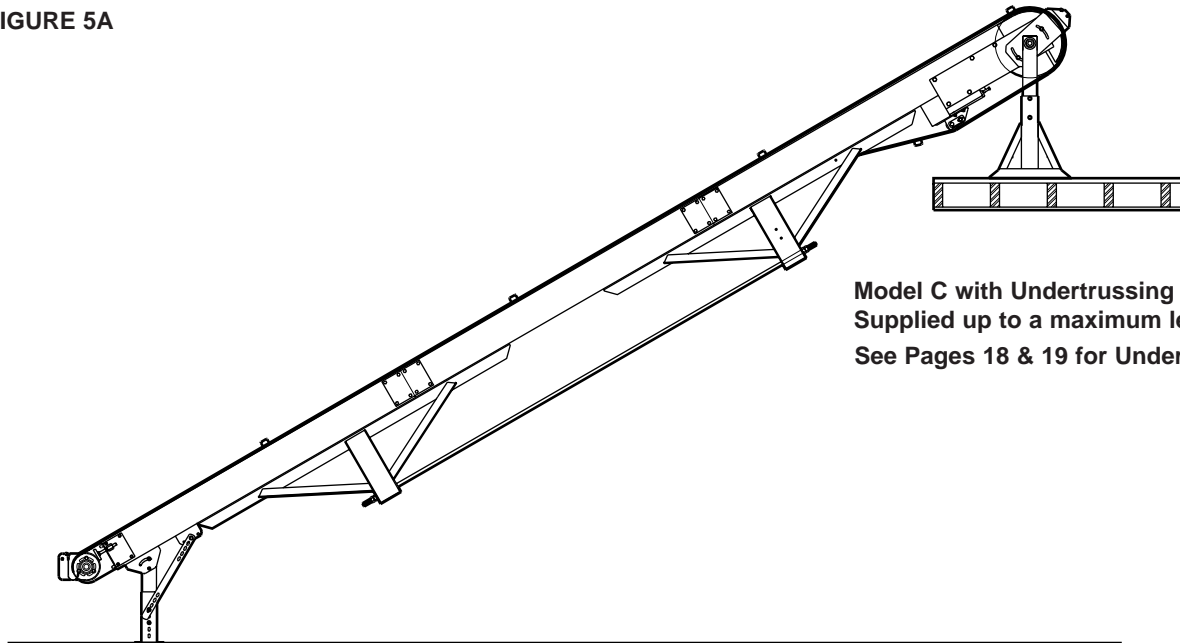
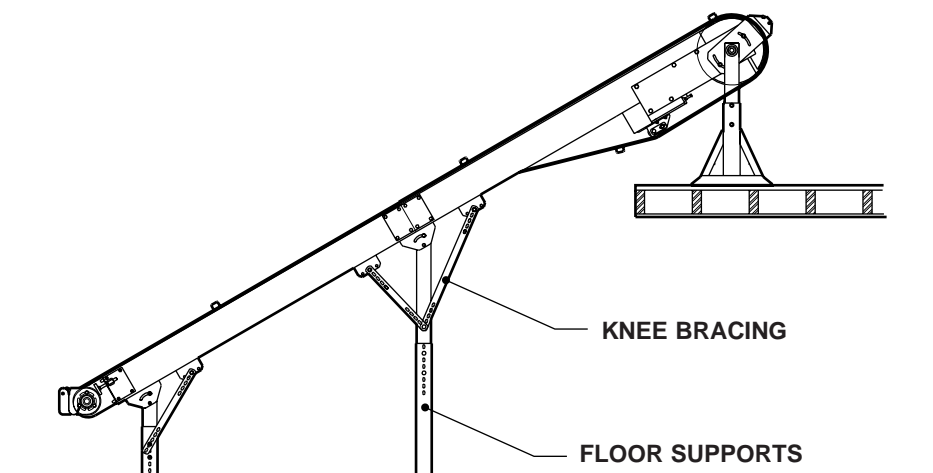

FIGURE 5A



Model C with Undertrussing
Supplied up to a maximum length of 40'
See Pages 18 & 19 for Undertrussing

Model C with floor supports
Supplied on all lengths over 40'



KNEE BRACING

FLOOR SUPPORTS

● Ceiling Hanger Installation

Ceiling Hangers can also be used to support an inclined conveyor.

Figure 6A shows how Ceiling Hanger Assembly mounts to conveyor bed section. It is important that Ceiling Hangers be mounted at every bed joint, so maximum support and rigidity is obtained.

NOTE: When installing ceiling hanger rods in an existing building, all methods of attachment must comply with local building codes.

For safety concerning conveyors mounted overhead, refer to "Installation Safety Precautions" on Page 3.

FIGURE 6A

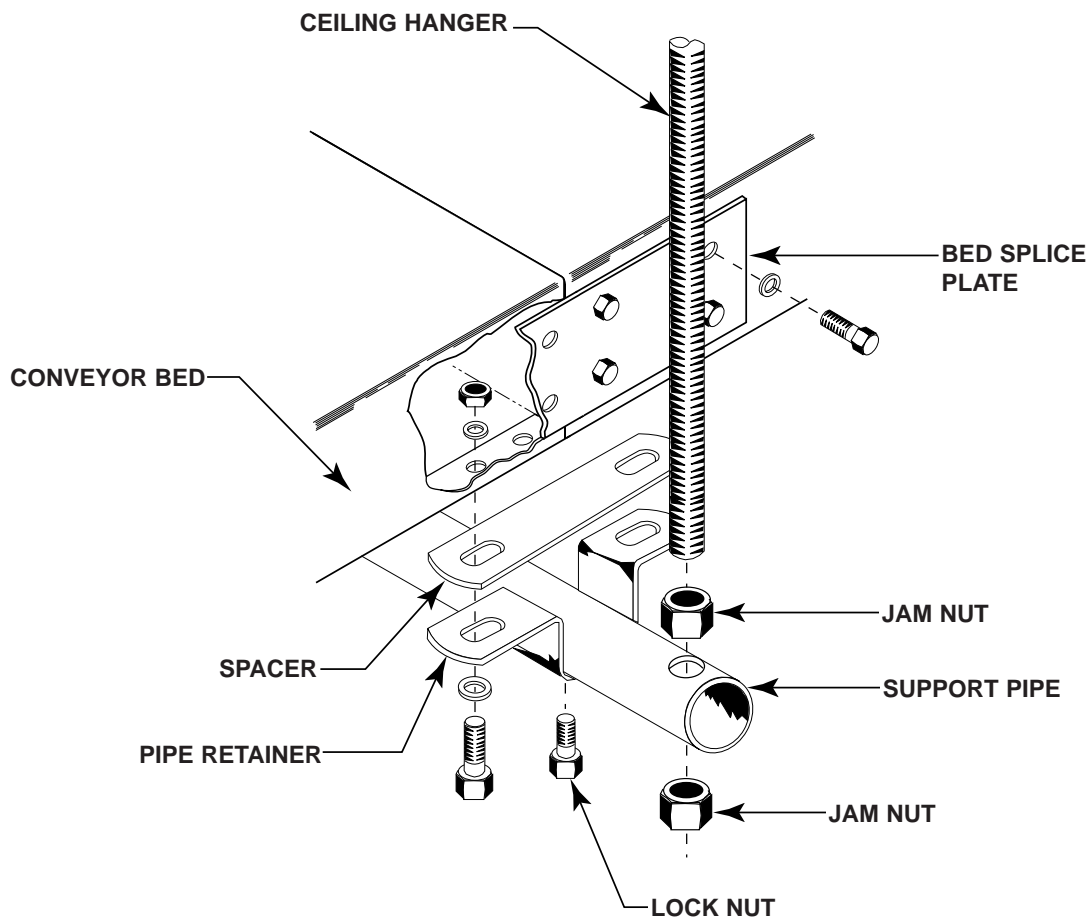

● Undertrussing - Model C



BED LENGTH **INFEED END**

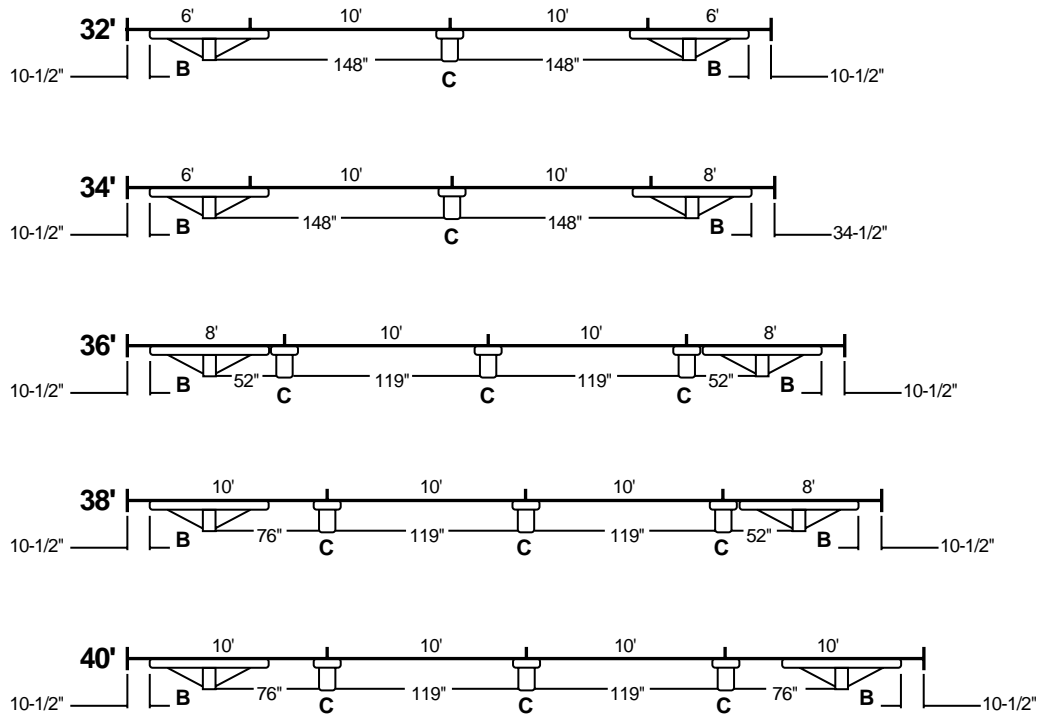

Ref. No.	Part No.	Description
A	B-13138	Joint Support (20 ft. Bed Length, FJ, C Only)
B	B-12639	Truss Rod End Bracket
C	B-12640	Truss Rod Center Bracket
D	B-12641	Truss Rod (Specify Length)
E	B-963	Cross Brace (Specify OAW)

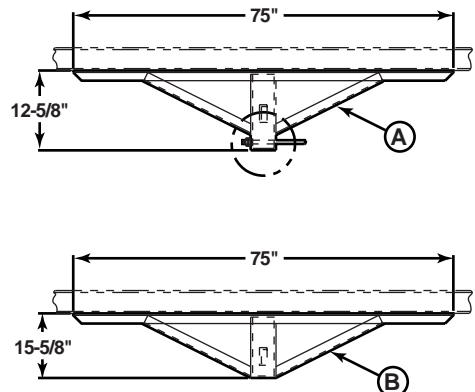

● Undertrussing - Model C



BED LENGTH INFEEED END

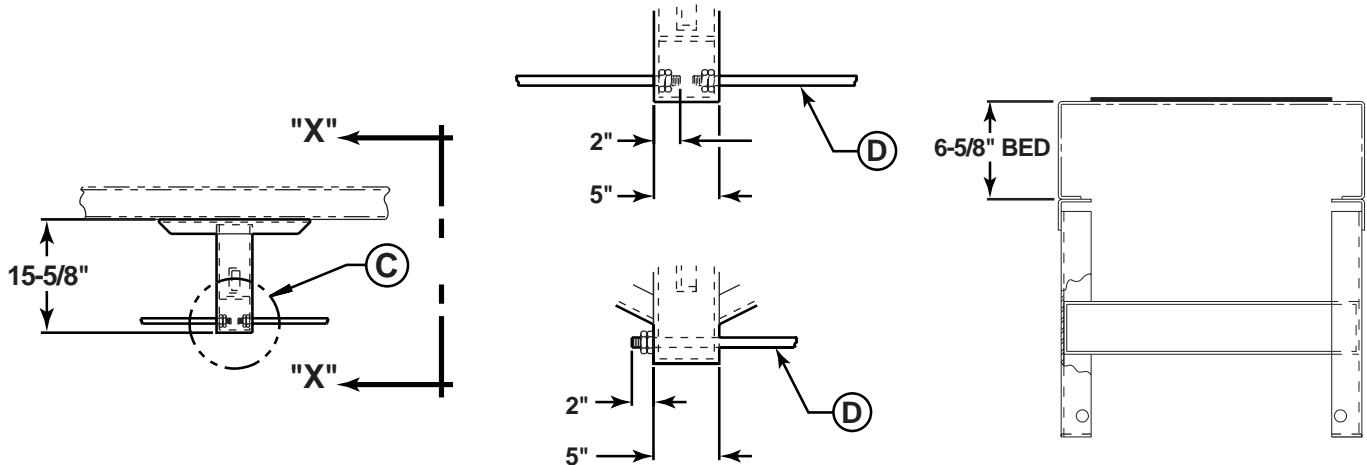
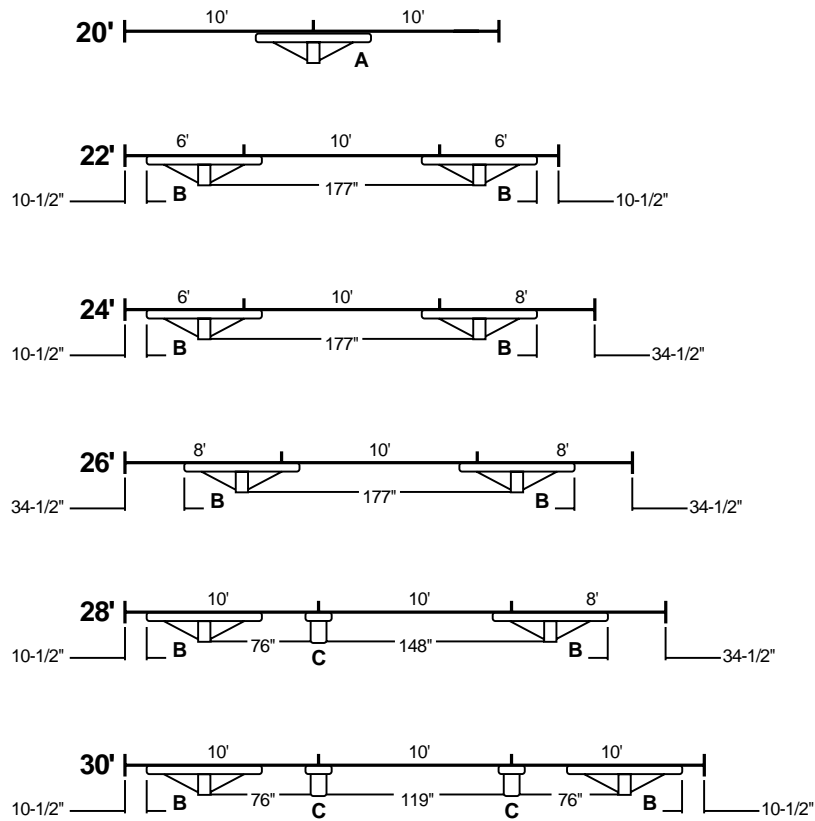

● Belt Installation

The conveyor drive belt has been pre-cut to the proper length and lacing installed at the factory. To install follow these steps:

1. . . Thread belt through conveyor as shown in Figure 7B.
2. . . Pull ends together and insert lacing pin (Figure 7A).
3. . . Adjust belt tension with take-up pulley or tail pulley. Keep pulley square by moving both take-up bolts an equal amount. Maintain enough tension so drive pulley will not slip when carrying the rated load.
4. . . Track belt per instructions on page 10 and 11.

NOTE: If belt ends cannot be pulled together by hand, it may be necessary to loosen take-up in center drive to minimum position or use a belt puller so lacing pin can be easily inserted.

CAUTION!
 Excessive slippage will reduce belt life and damage drive pulley lagging. Never apply more tension than is needed. Overtension will cause extra wear to belt and will require extra power from drive.

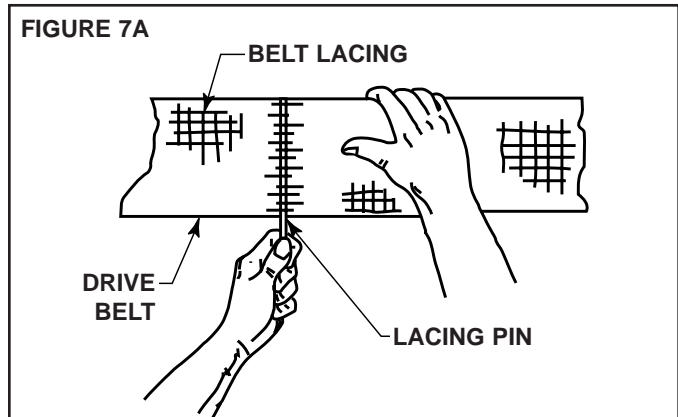
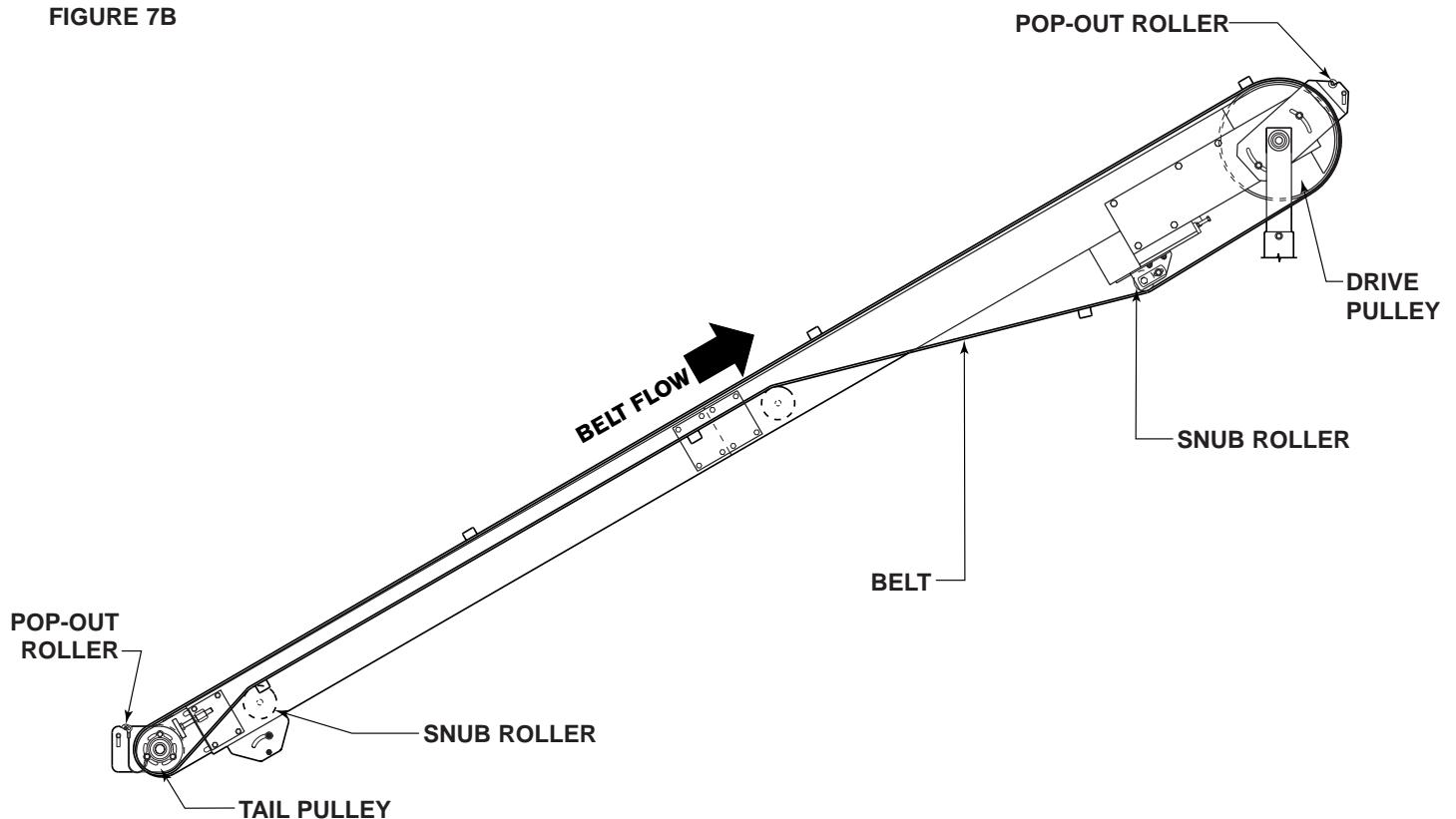

FIGURE 7B





● Electrical Equipment

WARNING!

Electrical controls shall be installed and wired by a qualified electrician. Wiring information for the motor and controls are furnished by the equipment manufacturer.

CONTROLS

Electrical Code: All motor controls and wiring shall conform to the National Electrical Code (Article 670 or other applicable articles) as published by the National Fire Protection Association and as approved by the American Standards Institute, Inc.

CONTROL STATIONS

A) Control stations should be so arranged and located that the operation of the equipment is visible from them, and shall be clearly marked or labeled to indicate the function controlled.

B) A conveyor which would cause injury when started shall not be started until employees in the area are alerted by a signal or by a designated person that the conveyor is about to start.

When a conveyor would cause injury when started and is automatically controlled or must be controlled from a remote location, an audible device shall be provided which can be clearly heard at all points along the conveyor where personnel may be present. The warning device shall be actuated by the controller device starting the conveyor and shall continue for a required period of time before the conveyor starts. A flashing light or similar visual warning may be used in conjunction with or in place of the audible device if more effective in particular circumstances.

Where system function would be seriously hindered or adversely affected by the required time delay or where the intent of the warning may be misinterpreted (i.e., a work area with many different conveyors and allied devices), clear, concise, and legible warning shall be provided. The warning shall indicate that conveyors and allied equipment may be started at any time, that danger exists, and that personnel must keep clear. The warnings shall be provided along the conveyor at areas not guarded by position or location.

C) Remotely and automatically controlled conveyors, and conveyors where operator stations are not manned

or are beyond voice and visual contact from drive areas, loading areas, transfer points, and other potentially hazardous locations on the conveyor path not guarded by location, position, or guards, shall be furnished with emergency stop buttons, pull cords, limit switches, or similar emergency stop devices.

All such emergency stop devices shall be easily identifiable in the immediate vicinity of such locations unless guarded by location, position, or guards. Where the design, function, and operation of such conveyor clearly is not hazardous to personnel, an emergency stop device is not required.

The emergency stop device shall act directly on the control of the conveyor concerned and shall not depend on the stopping of any other equipment. The emergency stop devices shall be installed so that they cannot be overridden from other locations.

D) Inactive and unused actuators, controllers, and wiring should be removed from control stations and panel boards, together with obsolete diagrams, indicators, control labels, and other material which serve to confuse the operator.

SAFETY DEVICES

A) All safety devices, including wiring of electrical safety devices, shall be arranged to operate in a "Fail-Safe" manner, that is, if power failure or failure of the device itself would occur, a hazardous condition must not result.

B) *Emergency Stops and Restarts.* Conveyor controls shall be so arranged that, in case of emergency stop, manual reset or start at the location where the emergency stop was initiated, shall be required of the conveyor(s) and associated equipment to resume operation.

C) Before restarting a conveyor which has been stopped because of an emergency, an inspection of the conveyor shall be made and the cause of the stoppage determined. The starting device shall be locked out before any attempt is made to remove the cause of stoppage, unless operation is necessary to determine the cause or to safely remove the stoppage.

Refer to ANSI Z244.1-1982, American National Standard for Personnel Protection – Lockout/Tagout of Energy Sources – Minimum Safety Requirements and OSHA Standard Number 29 CFR 1910.147 "The Control of Hazardous Energy (Lockout/Tagout)."

● Model C Parts List



See Page 15 For Information On
How To Order Replacement Parts

Recommended Spare Parts List Highlighted in Gray

Ref. No.	Part No.	Description
1	—	Motor—Foot Mounted
—	030.3044	3/4 HP—230/460 VAC—3 Ph.—60 Hz.—TEFC
—	030.4044	1 HP—230/460 VAC—3 Ph.—60 Hz.—TEFC
—	030.5034	1-1/2 HP—230/460 VAC—3 Ph.—60 Hz.—TEFC
—	030.6034	2 HP—230/460 VAC—3 Ph.—60 Hz.—TEFC
2	—	Speed Reducer
—	R-00152-020R	4A—RH—20:1 Ratio
—	R-00163-020R	5A—RH—20:1 Ratio
3	—	Sheave—Motor, 2.25 in. Dia.
—	020.101	Single Groove—5/8 in. Bore—3/4 HP
—	021.101	Double Groove—5/8 in. Bore—1 HP
—	021.110	Double Groove—7/8 in. Bore—1-1/2 & 2 HP
4	—	Sheave—Reducer, 5.45 in. Dia.
—	020.121	Single Groove—3/4 in. Bore—3/4 HP
—	021.108	Double Groove—3/4 in. Bore—1 thru 2 HP
5	—	V-Belt
—	066.105	4L270 (3/4—1 HP)
—	066.109	4L310 (1-1/2—2 HP)
6	—	Sprocket—Reducer
—	028.134	50B16 x 1 in. Bore (4A)
—	028.1342	50B16 x 1-1/4 in. Bore (5A)
7	—	Sprocket—Drive Pulley
—	027.100	50A30 x 1 in. Bore
—	027.102	50A30 x 1-1/4 in. Bore
8	090.202	Shaft Key—3/16 in. Sq. x 1 in. Long
9	090.203	Shaft Key—1/4 in. Sq. x 1 in. Long
10	029.101	#50 Riveted Roller Chain
11	029.201	Connector Link—#50 Roller Chain
12	B-00415	14" Dia. Dr. Pulley (Fully Lagged) (Specify OAW)
13	—	Drive Shaft (Specify)
—	B-00019	20 in. OAW
—	B-00421	24 in. OAW
—	B-00422	30 in. OAW
14	—	Spacer—Drive Shaft (Long) (Specify)
—	098.156	1 in. I.D. x 1-15/16 in. Long (20 in. OAW)
—	B-00424	1-1/4 in. I.D. x 1-15/16 in. Long (24 in. & 30 in. OAW)
15	—	Spacer—Drive Shaft (Short) (Specify)
—	098.155	1 in. I.D. x 11/16 in. Long (20 in. OAW)
—	B-00425	1-1/4 in. I.D. x 11/16 in. Long (24 in. & 30 in. OAW)
16	B-00133	Drive Plate Assembly—RH
17	B-00134	Drive Plate Assembly—LH
18	12.101	Roller Brg.—1 in I.D. x 1-1/2 in. Long with Split Race
19	B-00015	Bearing Retainer
20	093.107	Spring Clip—Bearing Retainer
21	092.103	Grease Fitting—1/8 NPT
22	049.3053	External Retaining Ring
23	B-04842	11/16 in. Hex Idler Bracket
24	G-00472	25 Roller Assembly (Specify Between Brackets)
25	B-00662	Drive Idler Bracket—RH
26	B-00663	Drive Idler Bracket—LH
27	—	Motor Base Assembly
—	B-10987	20 in. thru 30 in. OAW (4A) (Specify)
—	B-10988	24 in. thru 30 in. OAW (5A) (Specify)
28	040.307	Take-up Bolt—3/8-16 x 2-1/4 in. Long
29	041.300	Hex Jam Nut—Heavy—3/8-16
30	—	V-Belt Guard—Inside (Specify)
—	B-05275	3/4 & 1 HP—20 in. thru 30 in. OAW
—	B-05275	1-1/2 & 2 HP—20 in. OAW
—	B-05120	1-1/2 & 2 HP—24 in. thru 30 in. OAW
31	—	V-Belt Guard—Outside (Specify)
—	B-05274	3/4 & 1 HP—20 in. thru 30 in. OAW
—	B-05274	1-1/2 & 2 HP—20 in. OAW
—	B-05119	1-1/2 & 2 HP—24 in. thru 30 in. OAW

Ref. No.	Part No.	Description
32	B-06223	RH Gravity Bracket—Drive End
33	B-06238	LH Gravity Bracket—Drive End
34	B-02912	1 in. Dia. Pop-Out Roller (Specify OAW)
35	B-02624	Gravity Bar (Specify OAW)
36	—	Drive Bed Assembly
—	B-00183	6 ft. Long (Specify OAW)
—	B-00185	8 ft. Long (Specify OAW)
—	B-002136	10 ft. Long (Specify OAW)
37	—	Intermediate and Tail Bed Assembly
—	B-01254	6 ft. Long 20 in. OAW
—	B-01257	6 ft. Long 24 in. & 30 in. OAW (Specify)
—	B-01255	8 ft. Long 20 in. OAW
—	B-01258	8 ft. Long 24 in. & 30 in. OAW (Specify)
—	B-01256	10 ft. Long 20 in. OAW
—	B-02302	10 ft. Long 24 in. & 30 in. OAW (Specify)
38	B-00163	Splice Plate
39	B-01884	Bed Spacer (Specify OAW)
40	093.215	Return Roller Bracket
41	—	Spooled Idler Assembly
—	B-05587	20 in. & 24 in. OAW (Specify)
—	B-05585	30 in. OAW (Specify)
42	B-22221	4 in. Dia. Tail Pulley—20 in., 24 in. & 30 in. OAW (Specify)
43	B-21349-R	Take-up Plate Assembly—RH
44	B-21349-L	Take-up Plate Assembly—LH
45	B-21347-R	Adjustment Plate Assembly—RH
46	B-21347-L	Adjustment Plate Assembly—LH
47	041.919	Acorn Nut, 3/8-16
48	042.919	Shoulder Bolt, 1/2 in. Dia. x .312 Long
49	040.4065	Take-up Screw, 1/2-13 x 4 in. Long
50	041.201	Hex Jam Nut, 1/2-13
51	010.102	3-Bolt Flange Bearing, 1 in. Bore
52	B-09859	Nip Point Guard (Specify OAW)
53	B-02632	Gravity Bracket (Tail End)
54	—	Belt—Black Trackmate 447 Roughtop w/ PVC Cover (Specify Width)
55	—	U3 Clipper Unibar Lacing (Specify Length)
56	—	#13 Lacing Pin
57	099.105	Cleat—1-1/2 in. Dia. Wood
58	042.401	Elevator Bolt—5/16-18
59	041.101	Hex Nut, 5/16-18
60	B-00193	C-22 Support Frame—Drive End (Specify OAW)
61	B-00372	Adjustable Leg, C-22 Support
62	091.110	Cable Assembly
63	—	Undertrussing (See Page 18 & 19)
64	—	MS Type Pivot Plate—1-1/2 in. Flange
—	B-00913	3-11/16 in. High
—	B-02112	1-9/16 in. High
65	—	Floor Support Frame
—	B-00914	6 in. High (Specify OAW)
—	B-12777	7 in. High (Specify OAW)
—	B-12778	8 in. High (Specify OAW)
—	B-00915	9 in. High (Specify OAW)
—	B-00916	11-1/2 in. High (Specify OAW)
—	B-00917	14-1/2 in. High (Specify OAW)
—	B-02098	18-1/2 in. High (Specify OAW)
—	B-00919	22-1/2 in. High (Specify OAW)
—	B-00921	32-1/2 in. High (Specify OAW)
—	B-00923	44-1/2 in. High (Specify OAW)
—	B-00925	56-1/2 in. High (Specify OAW)
—	B-02107	68-1/2 in. High (Specify OAW)
—	B-02109	78-1/2 in. High (Specify OAW)
—	B-02111	90-1/2 in. High (Specify OAW)
66	B-00911	Adjustable Foot Assembly (Specify Length)
67	—	Knee Brace
—	B-00303	36 in. Long
—	B-00705	27 in. Long
68	B-01717	Knee Brace Bracket
69	B-06036	Support Splice Channel (Not Shown)

● Model C Parts Drawing

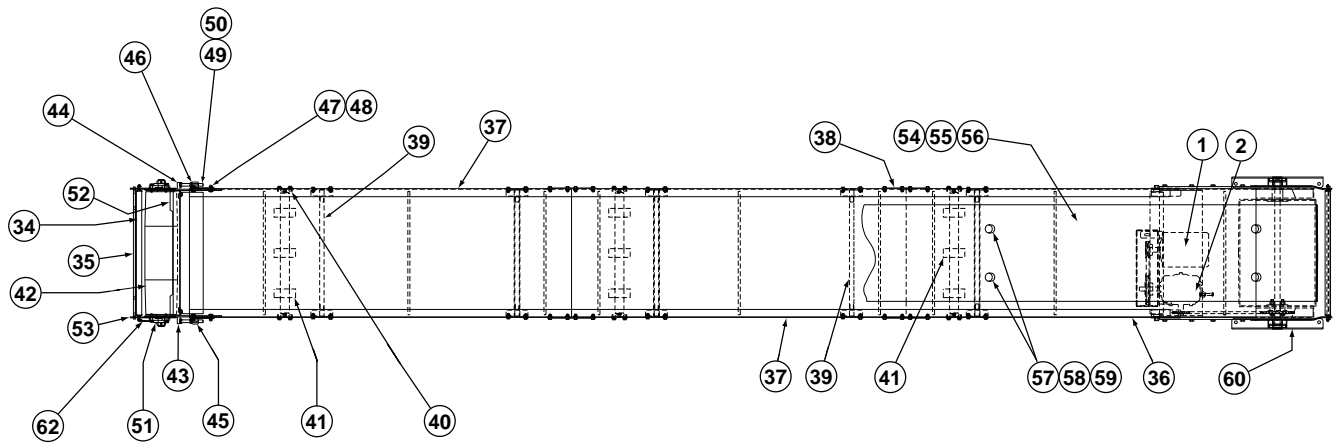
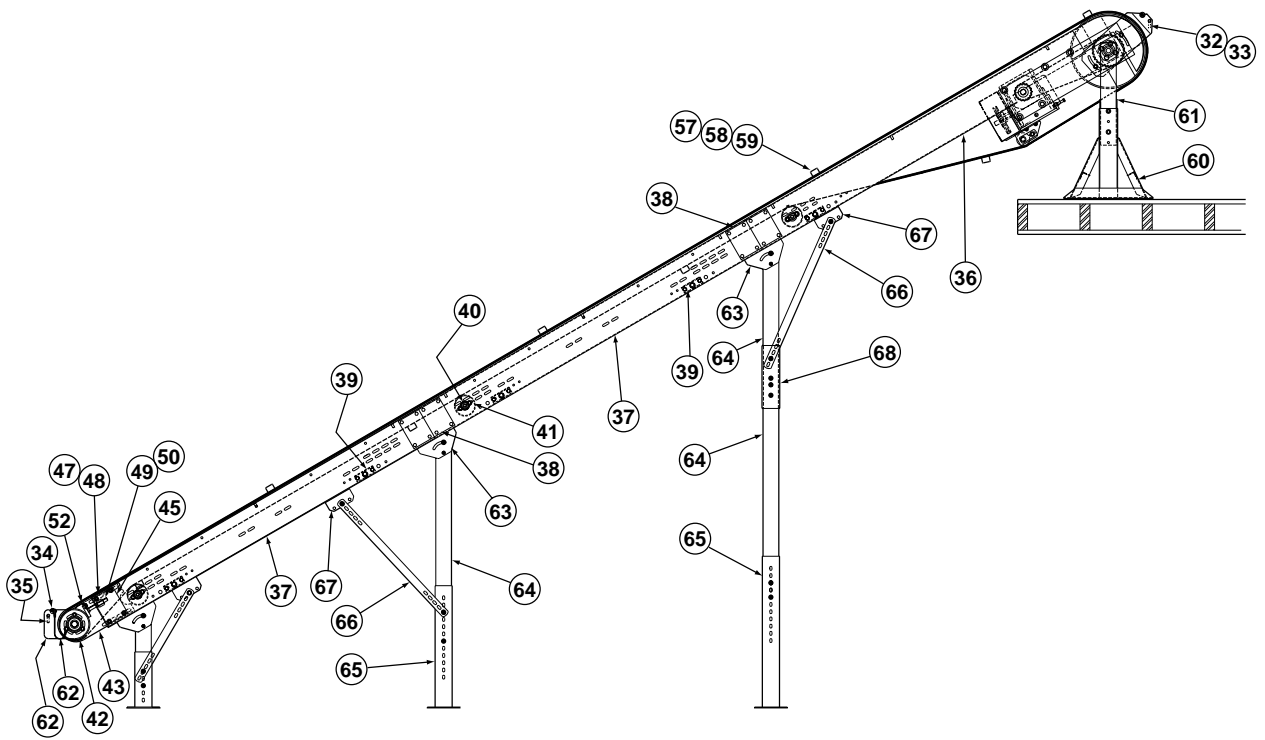
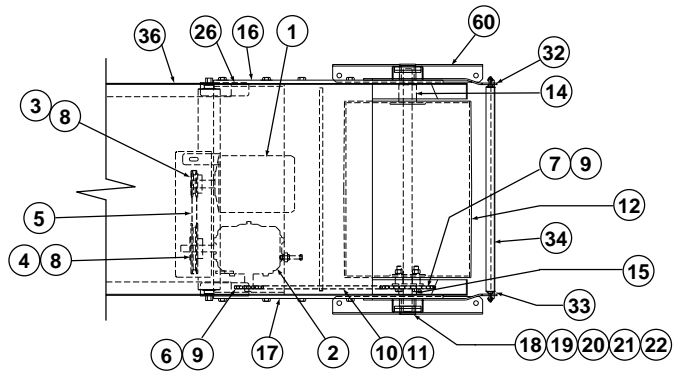
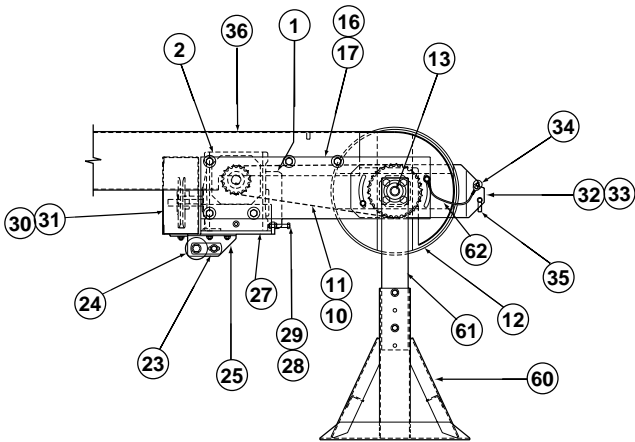

● Operation Safety Precautions

- A)** Only trained employees shall be permitted to operate conveyors. Training shall include instruction in operation under normal conditions and emergency situations.
- B)** Where employee safety is dependent upon stopping and/or starting devices, they shall be kept free of obstructions to permit ready access.
- C)** The area around loading and unloading points shall be kept clear of obstructions which could endanger personnel.
- D)** No person shall ride the load-carrying element of a conveyor under any circumstances unless that person is specifically authorized by the owner or employer to do so. Under those circumstances, such employee shall only ride a conveyor which incorporates within its supporting structure, platforms or control stations specifically designed for carrying personnel. Under no circumstances shall any person ride on any element of a vertical conveyor. Owners of conveyors should affix warning devices to the conveyor reading **Do Not Ride Conveyor**.
- E)** Personnel working on or near a conveyor shall be instructed as to the location and operation of pertinent stopping devices.
- F)** A conveyor shall be used to transport only material it is capable of handling safely.
- G)** Under no circumstances shall the safety characteristics of the conveyor be altered if such alterations would endanger personnel.
- H)** Routine inspections and preventive and corrective maintenance programs shall be conducted to insure that all safety features and devices are retained and function properly.
- I)** Personnel should be alerted to the potential hazard of entanglement in conveyors caused by items such as long hair, loose clothing, and jewelry.
- J)** As a general rule, conveyors should not be cleaned while in operation. Where proper cleaning requires the conveyor to be in motion and a hazard exists, personnel should be made aware of the associated hazard.

● Conveyor Start-Up

Before conveyor is turned on, check for foreign objects that may have been left inside conveyor during installation. These objects could cause serious damage during start-up.

After conveyor has been turned on and is operating, check motors, reducers, and moving parts to make sure they are working freely.

CAUTION!

Because of the many moving parts on the conveyor, all personnel in the area of the conveyor need to be warned that the conveyor is about to be started.

● Belt Tracking

HOW THE CONVEYOR BELT IS TRACKED

The belt is tracked by adjusting: Drive Pulley, Tail Pulley, Return Idlers, and Snub Idlers. The same tracking principles apply to conveyors supplied with end drives, center drives, or underside take-ups.

PRE-TRACKING INSPECTION

Before attempting to physically track the belt:

1. . . Make sure conveyor is level across the width and length of unit. Adjust supports as necessary.
2. . . Check to make sure: Drive Pulley, Tail Pulley, Snub Idlers, and all Return Idlers are square with conveyor bed. See illustration 10A, 10B, and 10C. Dimension "A" should be equal on both sides of unit.
3. . . Make sure belt has been properly threaded through conveyor. See "Belt Installation", Page 7.
4. . . Check for improper loading. Feed should be in direction of belt travel, centered on belt.
5. . . Make sure belt lacing has been installed correctly and is square with the belt.

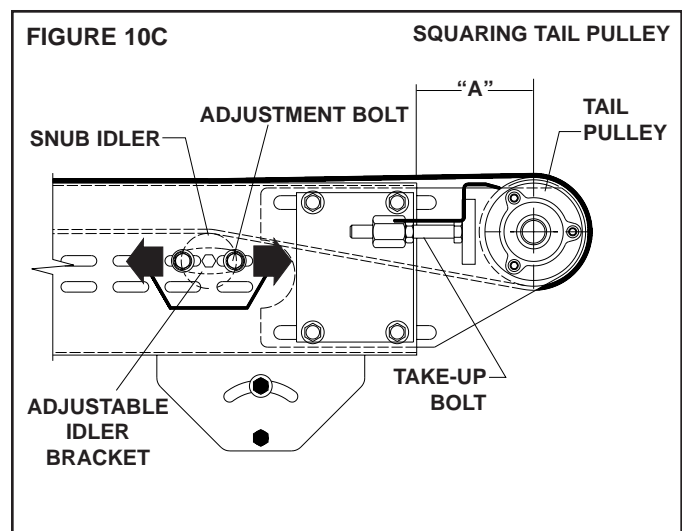
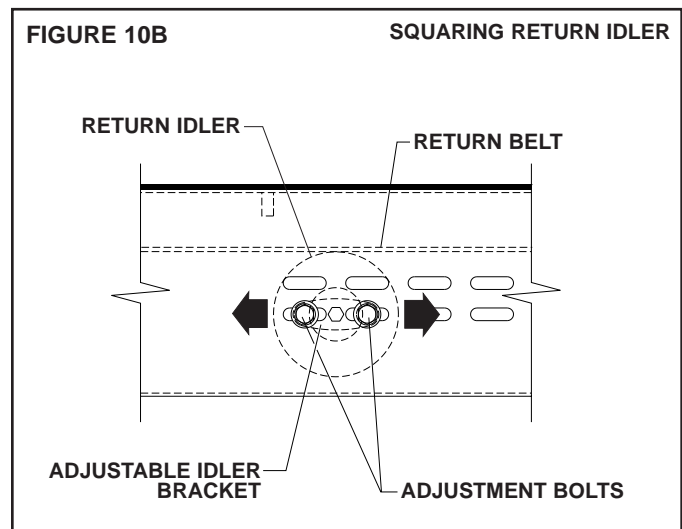
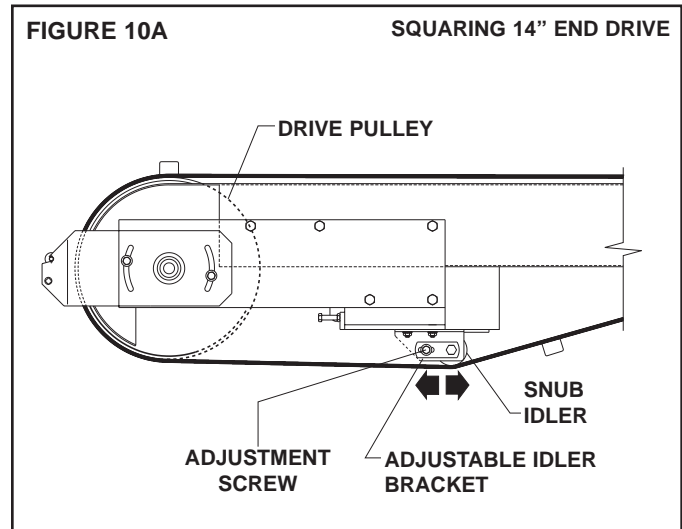

● Preventive Maintenance Checklist

The following is a general maintenance checklist which covers the major components of your conveyor.

This will be helpful in establishing a standard maintenance schedule.

COMPONENT	SUGGESTED ACTION	SCHEDULE		
		Weekly	Monthly	Quarterly
MOTOR	Check Noise			
	Check Temperature			
	Check Mounting Bolts			
REDUCER	Check Noise			
	Check Temperature			
	Check Oil Level			
BELT	Check Tracking			
	Check Tension			
	Check Lacing			
BEARINGS (Pulleys & Rollers)	Check Noise			
	Check Mounting Bolts			
DRIVE CHAIN	Check Tension			
	Lubricate			
	Check for Wear			
SPROCKETS	Check for Wear			
	Check Set Screws & Keys			
V-BELTS	Check Tension			
	Check for Wear			
	Check for Sheave Alignment			
STRUCTURAL	General Check: All loose bolts, etc., tightened			

● How to Order Replacement Parts

Included in this manual are parts drawings with complete replacement parts lists. Minor fasteners, such as nuts and bolts, are not included.

When ordering replacement parts:

1. . . Contact Dealer from whom conveyor was purchased or nearest HYTROL Distributor.
2. . . Give Conveyor Model Number and Serial Number or HYTROL Factory Order Number.
3. . . Give Part Number and complete description from Parts List.
4. . . If you are in a breakdown situation, tell us.



**HYTROL Serial Number
(Located near Drive
on Powered Models)**



● Trouble Shooting

The following charts list possible problems that may occur in the operation of a powered conveyor.

TROUBLE SHOOTING DRIVES

TROUBLE	CAUSE	SOLUTION
Conveyor will not start or motor quits frequently.	1) Motor is overloaded or drawing too much current.	1) Check for overloading of conveyor. 2) Check heater or circuit breaker and change if necessary.
Drive chain and sprockets wear excessively.	1) Lack of lubrication on chain causing chain stretch which creates improper chain to sprocket mesh. 2) Sprockets are out of alignment. 3) Loose chain.	1) Replace chain and sprockets. Provide adequate lubrication. NOTE: If problem reoccurs, a chain take-up may be required. 2) Align sprockets. See "Drive Chain Alignment and Tension" in this manual. 3) Tighten chain.
Loud popping or grinding noise.	1) Defective bearing. 2) Loose set screws in bearing. 3) Loose drive chain.	1) Replace bearing. 2) Tighten set screw. 3) Tighten chain.
Motor or reducer overheating.	1) Conveyor is overloaded. 2) Low voltage to motor. 3) Low lubricant level in reducer.	1) Check capacity of conveyor and reduce load to recommended level. 2) Have electrician check and correct as necessary. 3) Relubricate per manufacturer's recommendations. For HYTROL reducer, refer to separate manual.
Belt doesn't move, but drive runs.	1) Conveyor is overloaded. 2) Belt is too loose. 3) Lagging on drive pulley is worn.	1) Reduce load. 2) Use belt take-up to tighten belt. 3) Replace drive pulley lagging and tighten belt.

TROUBLE SHOOTING DRIVE BELT TRACKING

TROUBLE	CAUSE	SOLUTION
Entire length of belt creeps off at one spot only.	1) One or more idlers (usually near trouble spot) are out of line. 2) One conveyor section not level or square. 3) Material build-up on pulleys or idlers.	1) Adjust as necessary. See "Belt Tracking Pre-Tracking Inspection" in this manual for details. 2) Make necessary adjustments to supports. 3) Remove residue from pulleys or idlers. Install belt cleaners or scrapers if possible.
Entire belt creeps to one side at tail pulley.	1) Tail Pulley, Return Idler, or Snub Idler near Tail Pulley not properly aligned or square with bed.	1) Adjust as necessary. See "Belt Tracking, Pre-Tracking Inspection" in this manual on how to square Tail Pulley, Snub Idler, and Return Idler.
Entire belt creeps to one side.	1) Conveyor not straight. 2) Conveyor not level. 3) Material build-up on rollers, pulleys, or idlers.	1) Re-align bed sections as necessary. 2) Correct as necessary. 3) Remove residue and install belt cleaners or scrapers, if possible.

● Belt Tracking (Continued)

CAUTION!

Only trained personnel should track conveyor belt which must be done while conveyor is in operation.

IMPORTANT: When belt tracking adjustments are made, they should be minor (1/16 in. at a time on idlers, etc., should be sufficient).

Give the belt adequate time to react to the adjustments. It may take several complete revolutions around the conveyor for the belt to begin tracking properly on long, slow conveyor lines.

A) Stand at tail pulley looking toward drive and note what direction belt is traveling.

B) Having observed belt and determined tracking problem, follow procedures in "How to Steer The Belt", See Figure 11A.

HOW TO STEER THE BELT

Condition 1. . . . When the belt is running in the direction (FLOW) with the arrow, but tracking (drifting) towards Side "X", move the Snub Idler nearest the INFEED end of Side "Y" towards the DISCHARGE end of the conveyor.

Condition 2. . . . When the belt is running in the direction (FLOW) with the arrow, but tracking (drifting) towards Side "Y", move the Snub Idler nearest the INFEED end of Side "X" towards the DISCHARGE end of the conveyor.

If Belt Direction (FLOW) is reversed, all the above conditions will remain the same as in Figure 11A, **except you are now viewing the conveyor from the opposite end.**

If belt continues to track improperly, re-check all items covered in "Pre-Tracking Inspection" and make corrections as necessary.

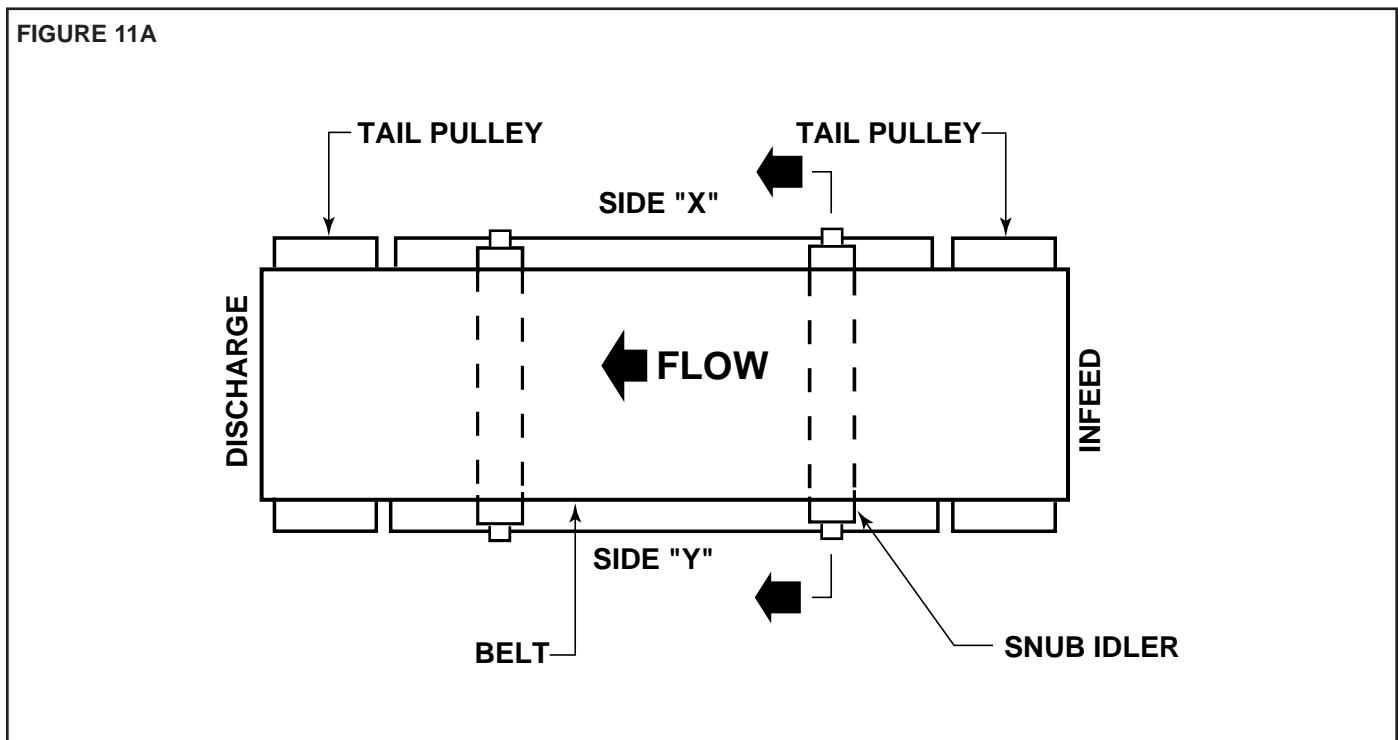

NOTE: In all conditions, you are viewing the Conveyor Belt from the INFEED end. All corrections will be made from the INFEED end of conveyor.

● Maintenance Safety Precautions

A) Maintenance, such as lubrication and adjustments, shall be performed only by qualified and trained personnel.

B) It is Important that a maintenance program be established to insure that all conveyor components are maintained in a condition which does not constitute a hazard to personnel.

C) When a conveyor is stopped for maintenance purposes, starting devices or powered accessories shall be locked or tagged out in accordance with a formalized procedure designed to protect all person or groups involved with the conveyor against an unexpected start.

D) Replace all safety devices and guards before starting equipment for normal operation.

E) Whenever practical, **DO NOT** lubricate conveyors while they are in motion. Only trained personnel who are aware of the hazard of the conveyor in motion shall be allowed to lubricate.

SAFETY GUARDS

Maintain all guards and safety devices **IN POSITION** and **IN SAFE REPAIR**.

WARNING SIGNS

Maintain all warning signs in a legible condition and obey all warnings. See Page 2 of this manual for examples of warning signs.

● Lubrication

BEARINGS

STANDARD: Supplied sealed and pre-lubricated. No lubrication required.

CHAIN

It is recommended that the drive chain be lubricated with SAE-30 oil approximately every 40 hours of operation. Under extreme conditions, more frequent lubrication may be required. (Also, See "Drive Chain Alignment and Tension".).

REDUCERS

MANUFACTURED BY HYTROL: See separate manual in Packing Envelope that contains lubrication and maintenance instructions for HYTROL's Gear Reducer.

MANUFACTURED BY OTHERS: Refer to their recommendations.

● Drive Chain Alignment and Tension

The drive chain and sprockets should be checked periodically for proper tension and alignment. Improper adjustment will cause extensive wear to the drive components.

TO MAKE ADJUSTMENTS

1. . . Remove chain guard.
2. . . Check sprocket alignment by placing a straightedge across the face of both sprockets. (Figure 13A.) Loosen set screws and adjust as needed. Re-tighten set screws.
3. . . To adjust chain tension, loosen bolts that fasten motor base to mounting angles, both sides of conveyor. Tighten take-up bolts until desired chain tension is reached. (Figures 13B & 13C). Re-tighten mounting bolts.
4. . . Make sure both sides are adjusted the same amount to prevent mis-alignment of sprockets. Re-tighten mounting bolts.
5. . . Lubricate chain per lubrication instructions.
6. . . Replace chain guard so that it does not interfere with drive.

CAUTION!

Never remove chain guards while the conveyor is running. Always replace guards after adjustments are made.

FIGURE 13A

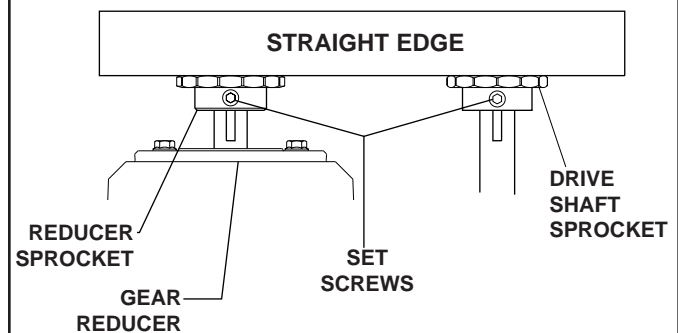

FIGURE 13B

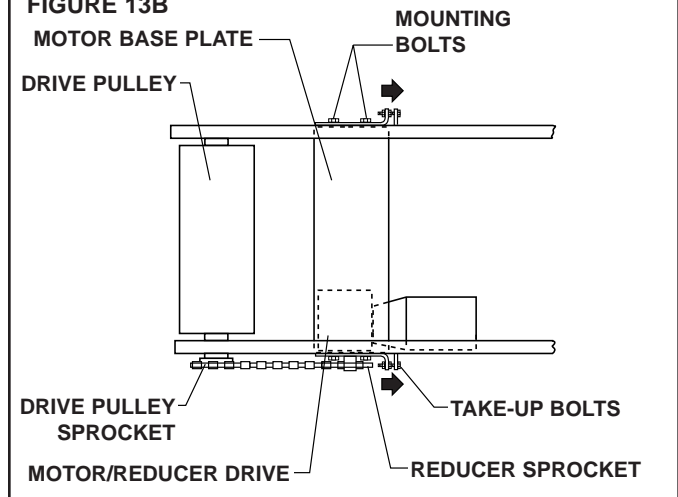
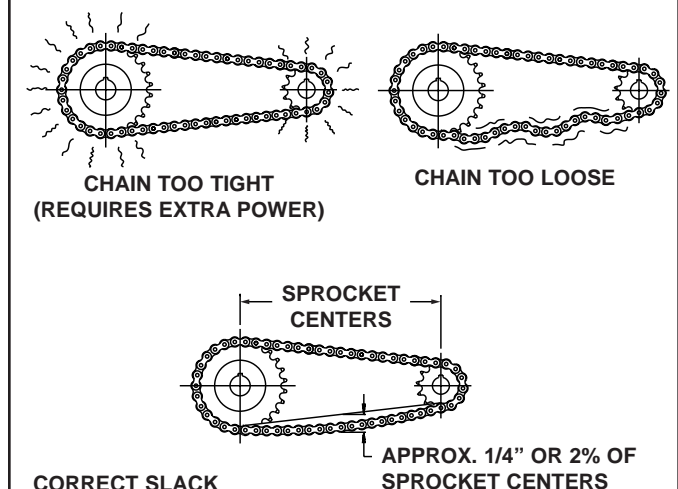

FIGURE 13C





HYTROL CONVEYOR COMPANY, INC.
2020 Hytrol Drive
Jonesboro, Arkansas 72401

Phone: (870) 935-3700
www.hytrol.com

EFFECTIVE NOVEMBER, 1998

Printed in the USA 11/98

